

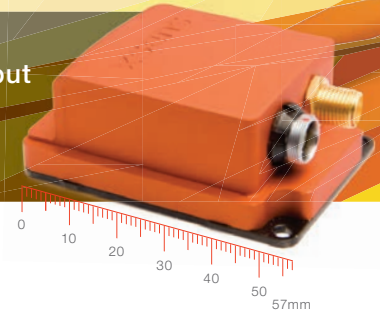

MTi-G-710

Turnkey GNSS/INS solution for navigation and stabilization applications

- ✓ All-in-one sensor system with high-frequency position and orientation output
- ✓ Excellent heading tracking without requiring a magnetic field
- ✓ Configurable output settings, synchronizes with any 3rd party device



Complete Xsens sensor fusion algorithm

- Compensation against long-lasting transient accelerations
- Ability to cope with GNSS outages
- Non-magnetic heading reference
- Tuned for performance under vibrations
- Selectable filter profiles for range of applications

Easy software integration

- Extensive suite of configurable output formats, calculated onboard the MTi-G-710
- MT Software Suite with intuitive GUI
- Complete SDK for all operating systems
- Support for Robotic Operating System (ROS)
- Xsens Xbus protocol or ASCII (NMEA)
- Access to BASE (by Xsens), an extensive knowledge base and community forum

Best-in-class hardware design

- Highest quality industrial grade components
- Vibration-rejecting gyroscopes and accelerometers
- Built-in multi-GNSS receiver (GPS, GLONASS, BeiDou, Galileo) and barometer
- Wide array of (time) synchronization options

Specification highlights

- True North without requiring a magnetic field
- IP67 encased version or OEM board
- Choice of several interfaces and onboard USB
- All Xsens products are fully interchangeable
- Cost-effective system integrator solution
- Position, velocity and orientation outputs

Product overview

		MTi-G-710 GNSS/INS
Calibrated Sensor Data		yes
Roll/pitch	Static	0.2°
	Dynamic	0.3°
Yaw		0.8°
Position and velocity		
Horizontal position	1σ STD (SBAS)	1.0 m
Vertical position	1σ STD (SBAS, baro)	2.0 m
Velocity accuracy	1σ RMS	0.05 m/s

All above specifications based on typical application scenarios

Sensor specification

	Gyroscopes	Accelerometers
Standard full range	+/- 450 °/s*	+/- 20 g
Initial bias error	0.2 %/s	5 mg
In-run bias stability	10 %/h	15 µg
Bandwidth (-3 dB)	415 Hz	375 Hz
Noise density	0.01 °/s/√Hz	60 µg/√Hz
g-sensitivity (calibrated)	0.003 %/s/g	N/A
Non-orthogonality	0.05 deg	0.05 deg
Non-linearity	0.01%	0.1%
	Magnetometer	Barometer
Standard full range	+/- 8 G	300-1100 hPa
Total RMS noise	0.5 mG	3.6 Pa
Non-linearity	0.2%	N/A
Resolution	0.25 mG	8 cm (sea level, 15 °C)
	GNSS receiver	
Receiver type	72-channel, 4 Hz GPS/QZSS L1 C/A, GLONASS L10F, BeiDou B1, SBAS L1 C/A: WAAS, EGNOS, MSAS	Horizontal accuracy (CEP) 2.0 m (SBAS) 2.5 m (Autonomous)
Start-up time cold start	26 s	Velocity accuracy (@30 m/s)
Tracking sensitivity	-167 dBm	0.05 m/s

* Optional +/- 1000 °/s available on request.

System specifications

Input voltage	4.5 to 34V or 3V3	Output frequency	Up to 2 kHz
Typical power consumption	750 mW @ 5V	Interfaces	RS232/RS422/RS485/USB UART
IP-rating	IP67 (encased)	Latency	<2 ms
Temperature (in use)	-40 to 85 °C	Clock drift	1 ppm or external reference
Vibration	MIL-STD-202-201A/204C/214A	Interface protocol	Xbus or ASCII (NMEA)
Sampling frequency	10 kHz/ch (60kS/s)	MTBF	300,000 hours
Sync options	SyncIn, SyncOut, Clock sync 1 PPS	Mounting orientation	No restriction, full 360° in all axes



MTi-G-710 Development Kit:
MTi-G-710, antenna, software
and cabling



MTi-G-710 encased:
57x42x23.5 mm, 55g,
9-pins push-pull connector



MTi-G-710 OEM:
37x33x12 mm, 11g,
16-pins header

