



3BE-UHF-XX-X ANTENNA FAMILY

3 Inch Blade Antenna for Wideband 800-2500 MHz Coverage

The 3BE-UHF-XX-X a 3 inch tall blade antenna for wideband applications. The rugged blade antenna enclosure is designed to survive ground and flight environments. The antenna includes 800-2500 MHz coverage in an ultra-low profile enclosure.

The antenna is easy to mount onto your platform using the four 10-32 screws provided. The installation kit includes an o-ring for sealing the enclosure to your platform.

Antcom can customize this product family to meet your specific requirements. Please contact us for more information about customization options.



BENEFITS

- Ultra low profile antenna for reduced aerodynamic drag
- Single antenna, multi-band operation
- Common mounting footprint for alternative frequency options

FEATURES

- Wideband coverage with a single connector
- Vertical polarized, omni directional coverage
- High power handling

OPTIONS

COLOR

- Gloss White
- Lusterless Gray
- Camo Green
- Lusterless Black
- Desert Tan

CONNECTOR

- SMA
- Type N
- TNC

ELECTRICAL

Frequency Range	
UHF/L/S- Bands	800-2500 MHz
VSWR	<2.5:1
Impedance	50 ohms

MECHANICAL & ENVIRONMENTAL

Designed to:

Weight	6.1 oz Typical
Temperature	-55°C TO +85°C
Altitude	70,000 ft
Vibration	> 30 Grms

LIMITING & FILTERING

Power Handling	50 Watt
----------------	---------

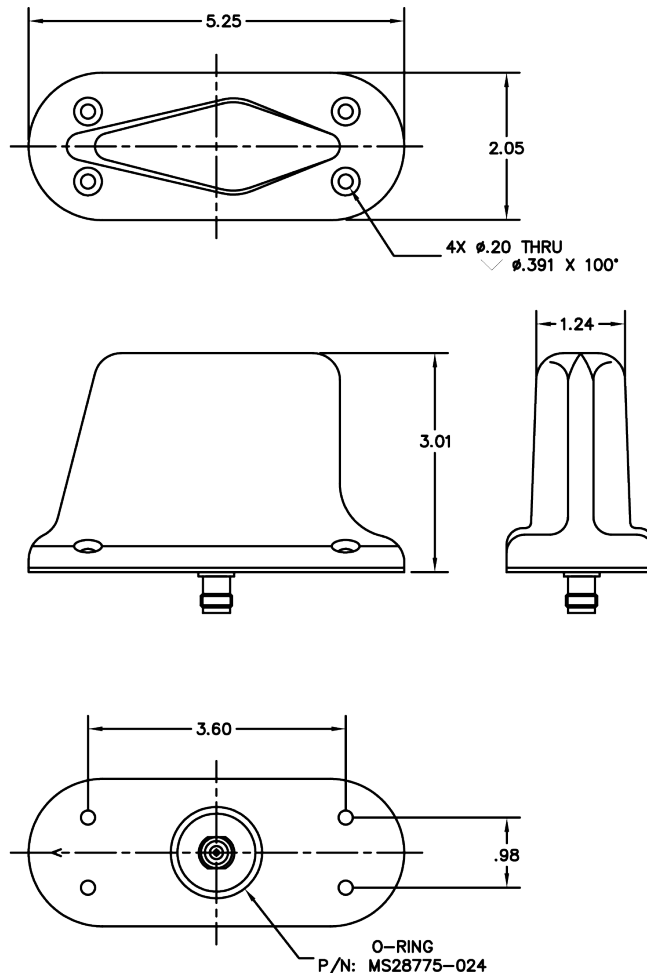

PART NUMBER DECODER

3BE-UHF-XX-X

Connector

- S = SMA
- T = TNC
- N = Type N
- TB = TNC-Bulkhead
- NB = N-Bulkhead

Color (PER FED-STD-595B)

- 1 = Gloss White #17925
- 2 = Lusterless Gray #36320
- 3 = Camo Green #34094
- 4 = Lusterless Black #37038
- 5 = Desert Tan #33446

CONTACT ANTCOM

Phone: +1-310-782-1076
 Fax: +1-310-782-1086
 Email: sales.pi.antcom@antcom.com
 Web: antcom.com

